

---

# MAINTENANCE

	Page
MAINTENANCE SCHEDULE .....	MA-2
MAINTENANCE OPERATIONS .....	MA-4
GENERAL MAINTENANCE .....	MA-18

**MA****GENERAL NOTES:**

- Every service item in the periodic maintenance list must be performed.
- Failure to do even one item can cause the engine to run poorly and increase exhaust emissions.

# MAINTENANCE SCHEDULE

Maintenance operations: A = Check and/or adjust if necessary;

R = Replace, change or lubricate;

I = Inspect and correct or replace if necessary

## NORMAL CONDITION SCHEDULE

System	Service interval (Odometer reading or months, whichever comes first)	Maintenance items	Maintenance services beyond 60,000 miles (96,000 km) should be performed at the same intervals shown in each maintenance schedule.									See page (item No.)
			Miles x 1,000	10	15	20	30	40	45	50	60	
			Km x 1,000	16	24	32	48	64	72	80	96	
			Months	12	18	24	36	48	54	60	72	
ENGINE	Valve clearance*						A				A	MA-7 (item 13)
	Drive belts <sup>(1)</sup>						I				I	MA-4 (item 1)
	Engine oil and oil filter*		R		R	R	R			R	R	MA-5 (item 6)
	Engine coolant <sup>(2)</sup>										R	MA-5 (item 7)
	Exhaust pipes and mountings						I				I	MA-7 (item 11)
FUEL	Idle speed	22R-E engine <sup>(3)</sup>	A				A				A	MA-8 (item 14)
	Idle speed and fast idle speed	22R engine <sup>(4)</sup>					A					MA-8 (item 14) MA-9 (item 15)
	Air filter*						R				R	MA-5 (item 5)
	Fuel lines and connections						I				I	MA-7 (item 10)
	Fuel filler cap gasket										R	MA-7 (item 9)
IGNITION	Spark plugs**						R				R	MA-4 (item 2)
EVAP	Charcoal canister	Calif. only									I	MA-6 (item 8)
EXHAUST	Oxygen sensor* <sup>(5)</sup>	Fed. 22R-E engine only									R	MA-7 (item 12)
BRAKES	Brake linings and drums				I		I		I		I	MA-11 (item 1)
	Brake pads and discs				I		I		I		I	MA-11 (item 18)
	Brake line pipes and hoses				I		I		I		I	MA-11 (item 16)
CHASSIS	Steering linkage				I		I		I		I	MA-11 (item 19)
	Ball joints and dust covers (RN 2WD)				I		I		I		I	MA-12 (item 21)
	Automatic transmission <sup>(6)</sup> , manual transmission, transfer (RN 4WD), differential and steering gear box <sup>(6)</sup> oil				I		I		I		I	MA-12 (item 20) MA-12 (item 22) MA-13 (item 23)
	Front wheel bearing grease						R				R	MA-14 (item 26)
	Steering knuckle and chassis grease (RN 4WD)				R		R		R		R	MA-14 (item 27)
	Propeller shaft grease (RN 4WD) <sup>(7)</sup>				R		R		R		R	MA-14 (item 27)
	Bolts and nuts on chassis and body				I		I		I		I	MA-16 (item 28)

Maintenance services indicated by a star (★) or asterisk (\*) are required under the terms of the Emission Control Systems Warranty. See Owner's Guide for complete warranty information.

★ For vehicles sold in California

\* For vehicles sold outside California

**NOTE:**

- (1) After 60,000 miles (96,000 km) or 72 months, inspect every 10,000 miles (16,000 km) or 12 months.
- (2) After 60,000 miles (96,000 km) or 72 months, replace every 30,000 miles (48,000 km) or 36 months.
- (3) After 30,000 miles (48,000 km) or 36 months, adjust every 30,000 miles (48,000 km) or 36 months.
- (4) Adjustment at 30,000 miles (48,000 km) or 36 months only
- (5) Replace at 60,000 miles (96,000 km) or 72 months only.
- (6) Inspect the automatic transmission and steering gear box for oil leakage only.
- (7) If the propeller shaft has been immersed in water, it should be re-greased within 24 hours.

Follow the severe condition schedule if vehicle is operated mainly under one or more of the following severe conditions:

- Pulling a trailer
- Repeated short trips
- Driving on rough and/or muddy roads
- Driving on dusty roads
- Driving in extremely cold weather and/or on salted roads

**SEVERE CONDITION SCHEDULE**

System	Service interval (Odometer reading or months, whichever comes first)	Maintenance services beyond 60,000 miles (96,000 km) should be performed at the same intervals shown in each maintenance schedule.																		See page (item No.)
		Miles x 1,000	5	7.5	10	15	20	22.5	25	30	35	37.5	40	45	50	52.5	55	60		
		Km x 1,000	8	12	16	24	32	36	40	48	56	60	64	72	80	84	88	96		
Maintenance items	Months	6	9	12	18	24	27	30	36	42	45	48	54	60	63	66	72			
ENGINE	Valve clearance*								A									A	MA-7 (item 13)	
	Drive belts <sup>(1)</sup>								I									I	MA-4 (item 1)	
	Engine oil and oil filter*	R		R	R	R			R	R	R		R	R	R		R	R	MA-5 (item 6)	
	Engine coolant <sup>(2)</sup>																	R	MA-5 (item 7)	
	Exhaust pipes and mountings				I				I				I					I	MA-7 (item 11)	
FUEL	Idle speed	22R-E engine <sup>(3)</sup>			A				A									A	MA-8 (item 14)	
	Idle speed and fast idle speed	22R engine <sup>(4)</sup>							A										MA-8 (item 14) MA-9 (item 15)	
	Air filter* <sup>(9)</sup>		I		I	I	I		I	R	I		I	I	I		I	R	MA-5 (item 4, 5)	
	Fuel lines and connections								I									I	MA-7 (item 10)	
	Fuel filler cap gasket																	R	MA-7 (item 9)	
IGNITION	Spark plugs**								R									R	MA-4 (item 2)	
	Ignition wiring and distributor cap**									(5)									MA-5 (item 3)	
EVAP	Charcoal canister	Calif. only																I	MA-6 (item 8)	
EXHAUST	Oxygen sensor* <sup>(6)</sup>	Fed. 22R-E engine only																R	MA-7 (item 12)	
BRAKES	Brake linings and drums		I		I			I		I		I		I		I		I	MA-11 (item 17)	
	Brake pads and discs		I		I			I		I		I		I		I		I	MA-11 (item 18)	
	Brake line pipes and hoses				I				I				I					I	MA-11 (item 16)	
CHASSIS	Steering linkage <sup>(10)</sup>		I		I			I		I		I		I		I		I	MA-11 (item 19)	
	Ball joints and dust covers (RN 2WD)		I		I			I		I		I		I		I		I	MA-12 (item 21)	
	Automatic transmission <sup>(7)</sup> , manual transmission, transfer (RN 4WD), differential and steering gear box <sup>(7)</sup> oil					R				R				R				R	MA-12 (item 20) MA-13 (item 24) MA-14 (item 25)	
	Front wheel bearing grease									R								R	MA-14 (item 26)	
	Steering knuckle and chassis grease (RN 4WD)		R		R				R		R		R		R		R	R	MA-14 (item 27)	
	Propeller shaft grease (RN 4WD) <sup>(8)</sup>		R		R				R		R		R		R		R	R	MA-14 (item 27)	
	Bolts and nuts on chassis and body <sup>(10)</sup>		I		I				I		I		I		I		I	I	MA-16 (item 28)	

Maintenance services indicated by a star (★) or asterisk (\*) are required under the terms of the Emission Control Systems Warranty. See Owner’s Guide for complete warranty information.

- ★ For vehicles sold in California
- \* For vehicles sold outside California

NOTE:

- (1) After 60,000 miles (96,000 km) or 72 months, inspect every 10,000 miles (16,000 km) or 12 months.
- (2) After 60,000 miles (96,000 km) or 72 months, replace every 30,000 miles (48,000 km) or 36 months.
- (3) After 30,000 miles (48,000 km) or 36 months, adjust every 30,000 miles (48,000 km) or 36 months.
- (4) Adjustment at 30,000 miles (48,000 km) or 36 months only.
- (5) In areas where road salt is used, inspect and clean each year just after the snow season.
- (6) Replace at 60,000 miles (96,000 km) or 72 months only
- (7) Inspect the automatic transmission and steering gear box for oil leakage only.
- (8) If the propeller shaft has been immersed in water, it should be re-greased within 24 hours.
- (9) Applicable when operating mainly on dusty roads. If not, follow the normal condition schedule.
- (10) Applicable when operating mainly on rough and/or muddy roads. If not, follow the normal condition schedule.

# MAINTENANCE OPERATIONS

## ENGINE

### Cold Engine Operations

#### 1. INSPECT DRIVE BELTS

(a) Visually check the drive belt for cracks, oiliness or wear. Check that the belt does not touch the bottom of the pulley groove.

If necessary, replace the drive belt.

(b) Using a belt tension gauge, check the drive belt tension.

Belt tension gauge:

Nippondenso BTG-20 (95506-00020) or

Borroughs No.BT-33-73F

**Drive belt tension: Used belt 80 ± 20 lb**

**New belt 125 ± 25 lb**

If necessary, adjust the drive belt tension.

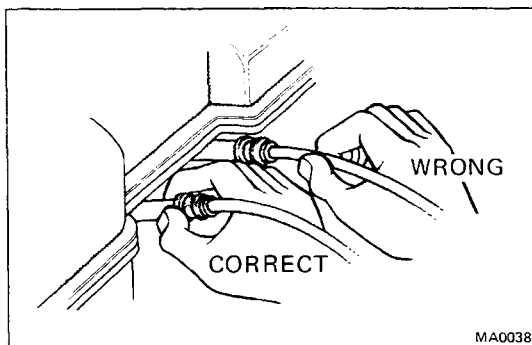
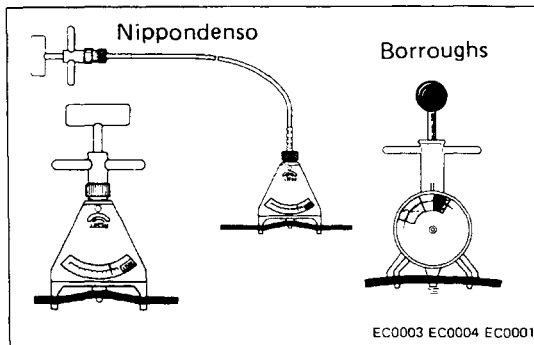
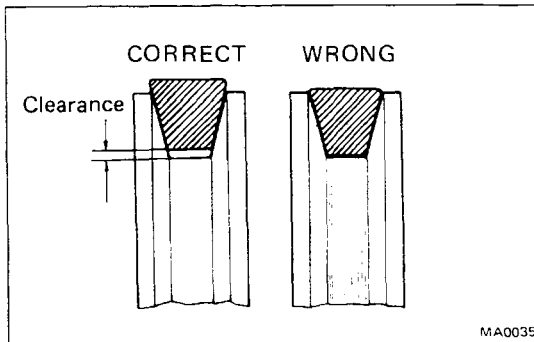

#### 2. REPLACE SPARK PLUGS

(a) Disconnect the spark plug wires at the boot. **DO NOT** pull on the wires.

(b) Remove the spark plugs.

(c) Set the gap on the new plugs.

**Gap: 0.8 mm (0.031 in.)**

Recommended spark plugs:

ND W16EXR-U

NGK BPR5EY

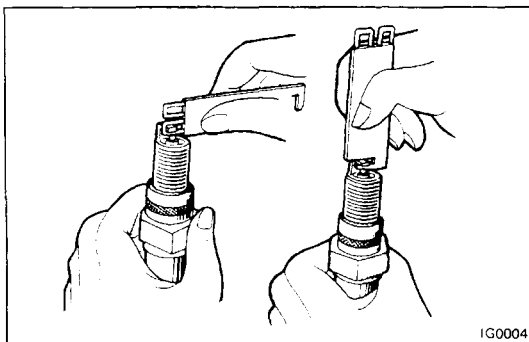

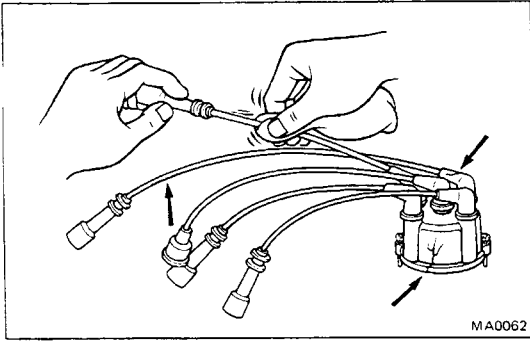

**3. INSPECT IGNITION WIRING AND DISTRIBUTOR CAP**

- (a) Remove the distributor cap with the wire.
- (b) Clean the distributor cap and wires with a clean cloth.
- (c) Visually inspect the wiring for cracks or damage.
- (d) Visually inspect the cap for cracks, carbon tracks or wear.

NOTE: In areas where road salt is used, inspection and cleaning should be performed each year just after the snow season.

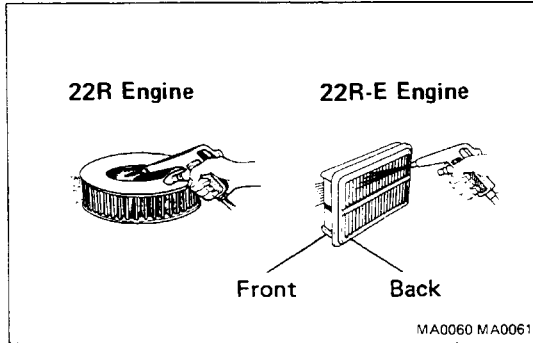

**4. INSPECT AIR FILTER**

- (a) Visually check that the air cleaner element is not excessively dirty, damaged or oily.

NOTE: Oiliness may indicate a stuck PCV valve.

If necessary, replace the air cleaner element.

- (b) Clean the element with compressed air.

First blow from inside (or back side) thoroughly, then blow off the outside (or front side) of the element.

**5. REPLACE AIR FILTER**

Replace the used air cleaner element with a new one.

**6. REPLACE ENGINE OIL AND OIL FILTER**

(See page LU-3)

Oil grade: **API grade SF or SF/CC multigrade, fuel-efficient and recommended viscosity oil.**

Engine oil capacity (Drain and refill with oil filter change): **4.6 liters (4.9 US qts, 4.0 Imp. qts)**

**7. REPLACE ENGINE COOLANT**

- (a) Drain the coolant from the radiator and engine drain cocks. (Engine drain is at left rear of engine block.)
- (b) Close the drain cocks.
- (c) Fill system with coolant.

Coolant capacity (w/heater or air conditioner):  
**8.4 liters (8.9 US qts, 7.4 Imp. qts)**

Use a good brand of ethylene-glycol base coolant, mixed according to the manufacturers instruction.

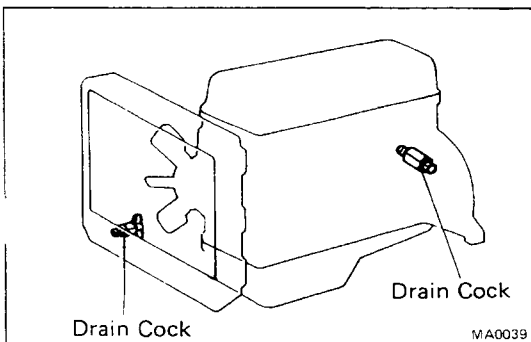

**8. CALIFORNIA VEHICLES ONLY:  
INSPECT CHARCOAL CANISTER**

**A. 22R-E ENGINE**

- (a) Disconnect the hoses to the charcoal canister.  
Label hoses for correct installation.

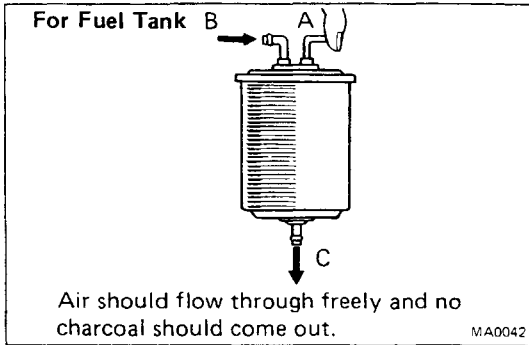

- (b) Plug pipe A with your finger and blow compressed air (3 kg/cm<sup>2</sup>, 43 psi or 294 kPa) through pipe B (fuel tank side).
- Check that air comes out of the bottom pipe C without resistance.
  - Check that no activated charcoal comes out.

If necessary, replace the charcoal canister.

NOTE: Do not attempt to wash the charcoal.

- (c) Connect the hoses to the charcoal canister.

**B. 22R ENGINE**

- (a) Inspect the fuel tank and carburetor charcoal canisters.

For Fuel Tank

- (b) Disconnect the hoses to the fuel tank charcoal canister. Label hoses for correct installation.
- (c) Plug pipe A with your finger and blow compressed air (3 kg/cm<sup>2</sup>, 43 psi or 294 kPa) through pipe B (fuel tank side).
- Check that air comes out of the bottom pipe C without resistance.
  - Check that no activated charcoal comes out.

If necessary, replace the charcoal canister.

NOTE: Do not attempt to wash the charcoal.

- (d) Connect the hoses to the charcoal canister.

For Carburetor

- (e) Disconnect the hoses to the carburetor charcoal canister located below the battery. Label hoses for correct installation.
- (f) Plug pipe A with your finger and blow compressed air (3 kg/cm<sup>2</sup>, 43 psi or 294 kPa) through pipe B (Outer vent control valve side).
- Check that air comes out of the bottom pipe C without resistance.
  - Check that no activated charcoal comes out.

If necessary, replace the charcoal canister.

NOTE: Do not attempt to wash the charcoal.

- (g) Connect the hoses to the charcoal canister.

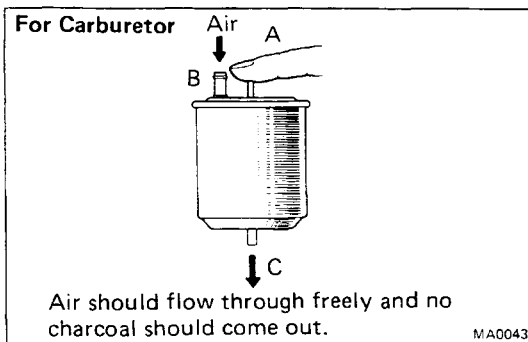
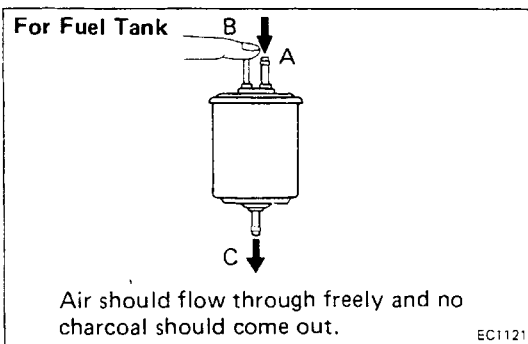

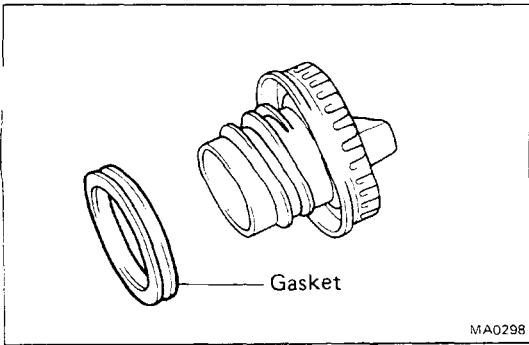

**9. REPLACE GASKET IN FUEL FILLER CAP**

- (a) Remove the old gasket (O-ring) from the fuel filler cap. Do not damage the cap.
- (b) Install the new gasket by hand.
- (c) Inspect the cap for damage or cracks.
- (d) Install the cap and check the torque limiter.

**10. INSPECT FUEL LINES AND CONNECTIONS**

(22R Engine: See page FU-30)

(22R-E Engine: See page FI-53)

Visually inspect the fuel lines for cracks, leakage or loose connections.

**11. INSPECT EXHAUST PIPES AND MOUNTINGS**

Visually inspect the pipes, hangers and connections for severe corrosion, leaks or damage.

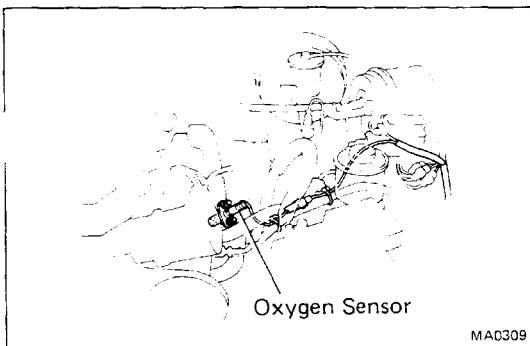

**12. FEDERAL 22R-E ENGINE ONLY:  
REPLACE OXYGEN SENSOR**

- (a) Disconnect the oxygen sensor wiring connector.
- (b) Remove the oxygen sensor and gasket from the exhaust manifold.
- (c) Install the new gasket and oxygen sensor to the exhaust manifold.

**Torque: 200 kg-cm (14 ft-lb, 20 N·m)**

- (d) Inspect oxygen sensor operation. Inspect feed back control. (See page FI-69)

**Hot Engine Operations**

**13. ADJUST VALVE CLEARANCE**

- (a) Warm up the engine to normal operating temperature.
- (b) Stop the engine and remove the valve cover.
- (c) Set No. 1 cylinder to TDC/compression.
  - Turn the crankshaft with a wrench to align the timing marks at TDC. Set the groove on the pulley to the O position.
  - Check that the rocker arms on No. 1 cylinder are loose and rockers on No. 4 are tight.

If not, turn the crankshaft one complete revolution and align marks as above.

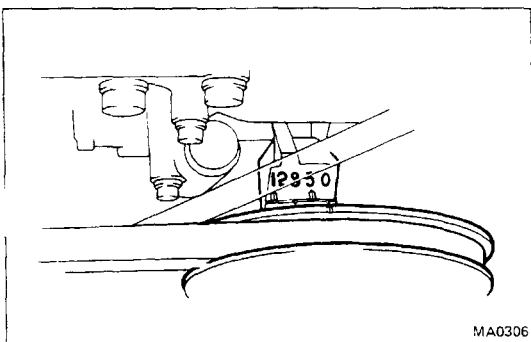

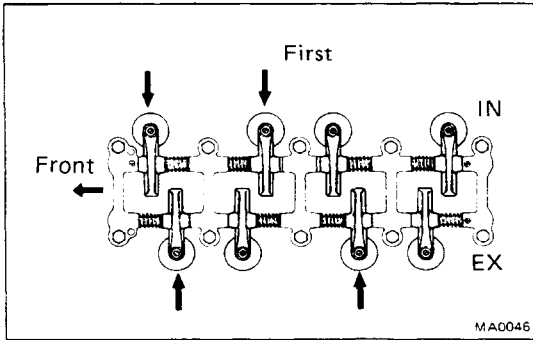

(d) Adjust the clearance of half of the valves.

- Adjust only those valves indicated by arrows.

Valve clearance: Intake 0.20 mm (0.008 in.)  
Exhaust 0.30 mm (0.012 in.)

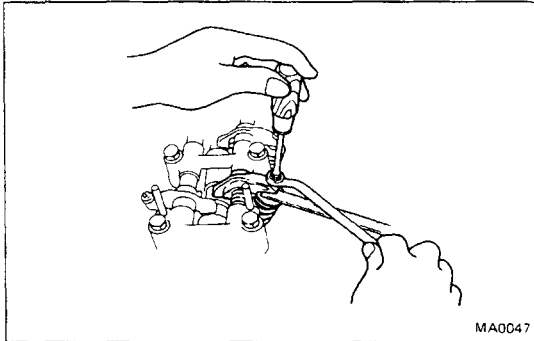

- Use a feeler gauge to measure between the valve stem and rocker arm. Loosen the lock nut and turn the adjusting screw to set the proper clearance. Hold the adjusting screw in position, and tighten the lock nut.
- Recheck the clearance. The feeler gauge should move with a very slight drag.

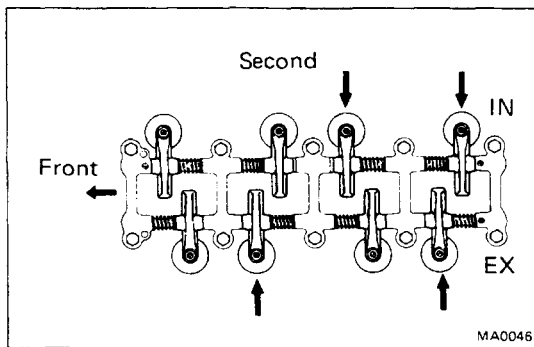

(e) Turn the crankshaft one complete revolution (360°) and align timing marks in the manner mentioned above. Adjust only the valves indicated by arrows.

(f) Reinstall the valve cover.

(g) Reinstall the air cleaner (22R engine).

## 14. ADJUST IDLE SPEED

### A. 22R-E ENGINE

#### (a) Preparation

- Air cleaner installed
- All pipes and hoses of air intake system connected
- All vacuum lines connected (i. e., SC, EGR systems, etc.)
- EFI system wiring connectors fully plugged
- Engine at normal operating temperature
- Accessories switched off
- Transmission in N range

(b) Connect a tachometer to the engine.

Connect the tachometer positive (+) terminal to the ignition coil negative (-) terminal.

#### CAUTION:

1. NEVER allow the tachometer terminal to touch ground as it could result in damage to the igniter and/or ignition coil.
2. As some tachometers are not compatible with this ignition system, it is recommended that you consult with the manufacturer.

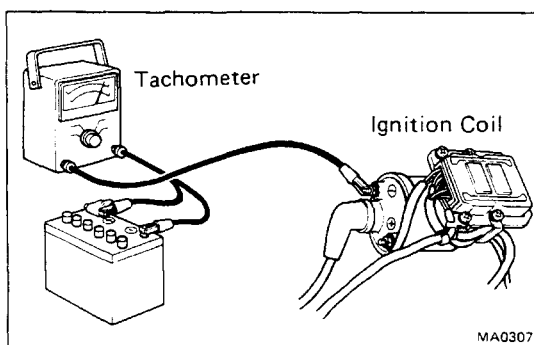

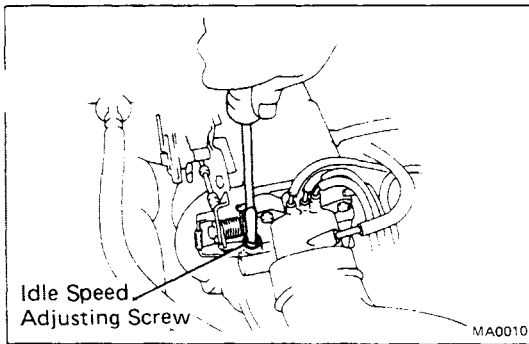

- (c) Race the engine at 2,500 rpm for about 2 minutes.
- (d) Set the idle speed by turning the IDLE SPEED ADJUSTING SCREW.

**Idle speed: 750 rpm**

- (e) Remove the tachometer.

**B. 22R ENGINE**

- (a) Preparation

- Air cleaner installed
- Choke valve fully open
- Accessories switched off
- All vacuum lines connected (i.e., AS, EGR systems, etc.)
- Transmission in N range
- Engine idling at normal operating temperature

- (b) Connect a tachometer to the engine.

Remove the rubber cap and connect the tachometer positive (+) terminal to the service connector at the igniter.

**CAUTION:**

1. **NEVER** allow the tachometer terminal to touch ground as it could result in damage to the igniter and/or ignition coil.
2. **As some tachometers are not compatible with this ignition system, it is recommended that you consult with the manufacturer.**

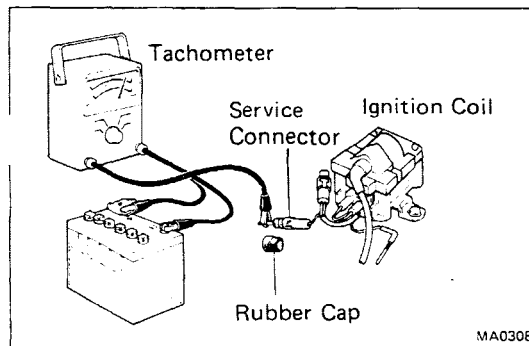

- (c) Set the idle speed by turning the IDLE SPEED ADJUSTING SCREW.

**Idle speed: 700 rpm M/T  
750 rpm A/T**

**NOTE:** Leave the tachometer connected for further adjustment.

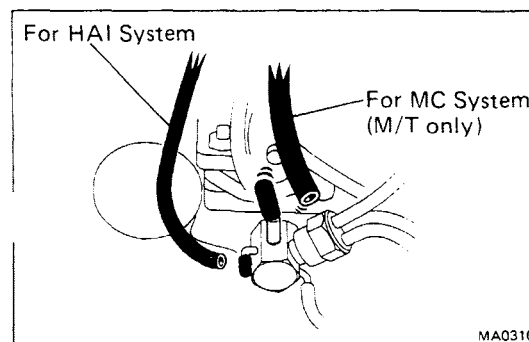
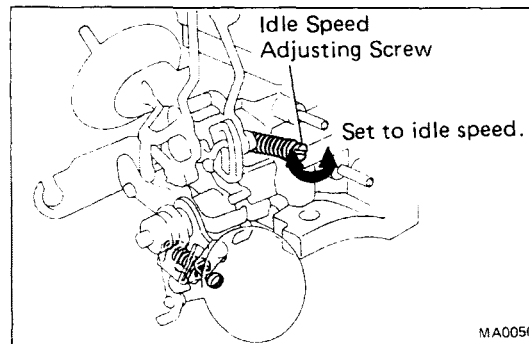

**15. 22R ENGINE ONLY:  
ADJUST FAST IDLE SPEED**

- (a) Stop the engine and remove the air cleaner.
- (b) Plug the hose connections for HAI system and MC system (w/M/T only) to prevent rough idling.

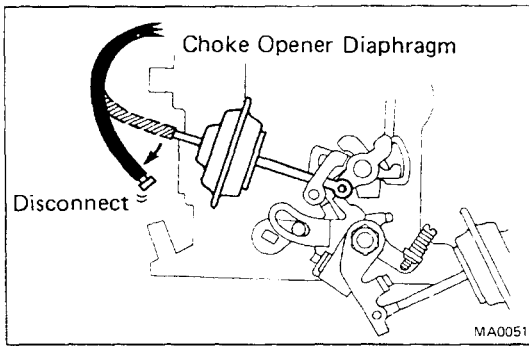

- (c) Disconnect the hose from the choke opener diaphragm and plug the hose end. This will shut off the choke opener system.

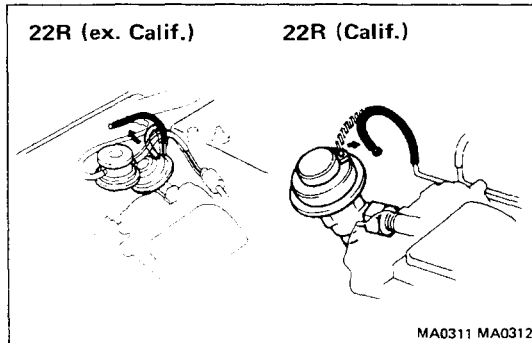

- (d) Disconnect the hose from the EGR valve. This will shut off the EGR system.

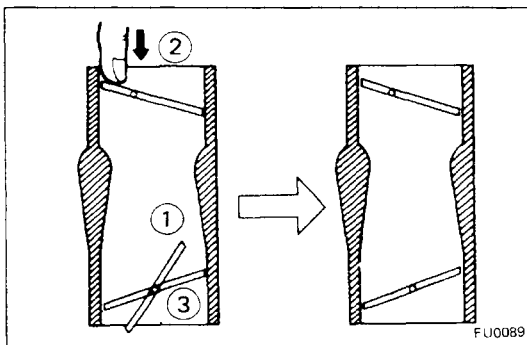

- (e) Set the fast idle cam. While holding the throttle valve slightly open, push the choke valve closed, and hold it closed as you release the throttle valve.
- (f) Start the engine, but do NOT touch the accelerator pedal.

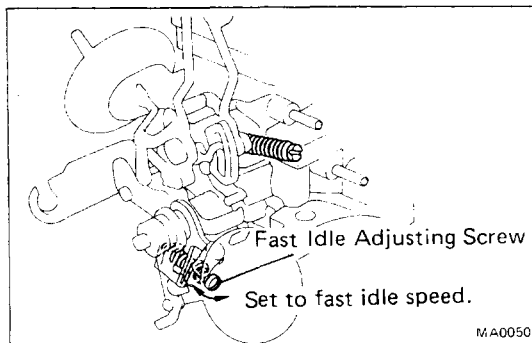

- (g) Set the fast idle speed by turning the fast idle adjusting screw.

**Fast idle speed: 2,600 rpm**

- (h) Reconnect the vacuum hoses to the proper locations.
- (i) Reinstall the air cleaner.
- (j) Stop the engine and remove the tachometer.

## BRAKES

### 16. INSPECT BRAKE LINE PIPES AND HOSES

NOTE: Inspect in a well lighted area. Inspect the entire circumference and length of the brake hoses using a mirror as required. Turn the front wheels fully right or left before inspecting the front brake.

- (a) Check all brake lines and hoses for:
  - Damage
  - Wear
  - Deformation
  - Cracks
  - Corrosion
  - Leaks
  - Bends
  - Twists
- (b) Check all clamps for tightness and connections for leakage.
- (c) Check that the hoses and lines are clear of sharp edges, moving parts and the exhaust system.
- (d) Check that the lines installed in grommets pass through the center of the grommets.

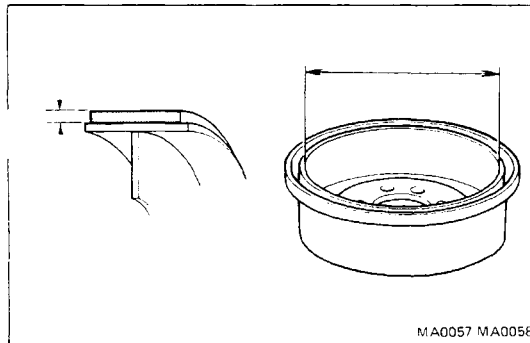
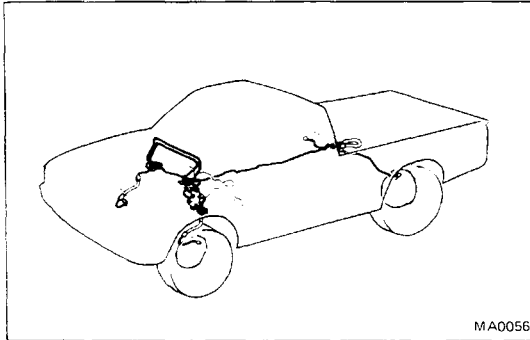
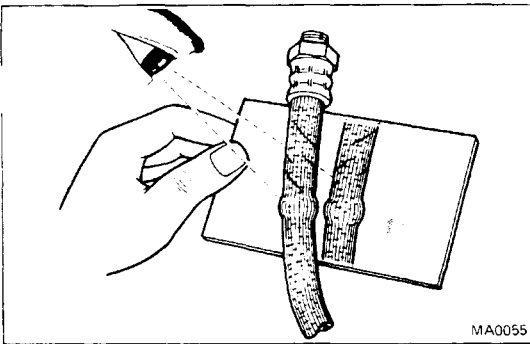

### 17. INSPECT REAR BRAKE LININGS AND DRUMS

(2WD: See page BR-30 or BR-37, 4WD: See page BR-43)

- (a) Check the linings for wear.

**Minimum lining thickness: 1.0 mm (0.039 in.)**

- (b) Check the brake drums for scoring or wear.

**Maximum drum inside diameter: 256.0 mm (10.079 in.)**

- (c) Clean the brake parts with a damp cloth.

NOTE: Do not use compressed air to clean the brake parts.

### 18. INSPECT FRONT BRAKE PADS AND DISCS

(2WD: See page BR-13 or BR-19, 4WD: See page BR-25)

- (a) Check the thickness of the disc brake pads and check for irregular wear.

**Minimum pad thickness: 1.0 mm (0.039 in.)**

- (b) Check the disc for wear or runout.

**Minimum disc thickness:**

RN 2WD 1/2 ton	21.0 mm (0.827 in.)
1 ton and C&C	24.0 mm (0.945 in.)
RN 4WD	11.5 mm (0.453 in.)

**Maximum disc runout: 0.15 mm (0.0059 in.)**

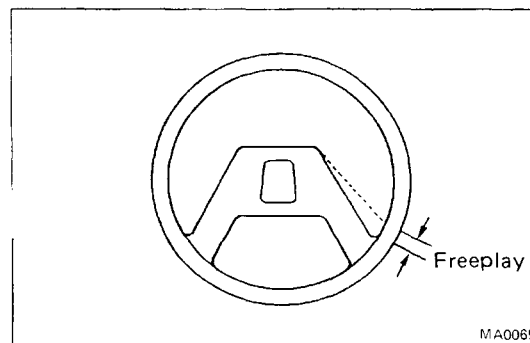
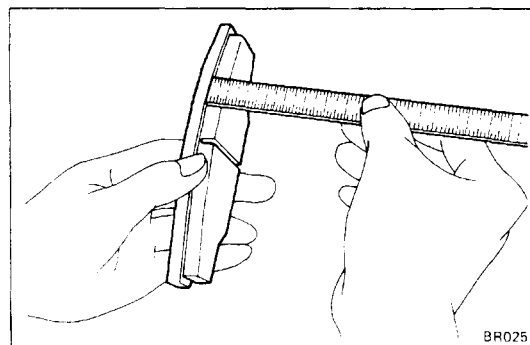

## CHASSIS

### 19. INSPECT STEERING LINKAGE

- (a) Check that the steering wheel freeplay is:

**Maximum: 30 mm (1.18 in.)**

With the vehicle stopped and pointed straight ahead, rock the steering wheel gently back and forth with light finger pressure.

If incorrect, adjust or repair.

RN 2WD

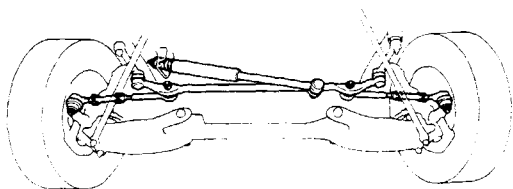

RN 4WD

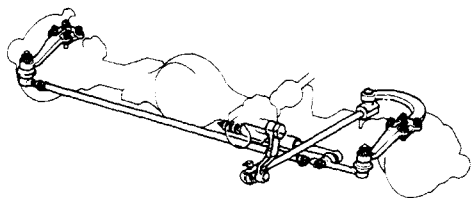

MA0069  
MA0059

(b) Check the steering linkage for looseness or damage. Check that:

- Tie rod ends and relay rod ends do not have excessive play.
- Dust seals are not damaged.

**20. INSPECT STEERING GEAR BOX OIL**

Check the steering gear box for oil leaks. If leakage is found, check for cause and repair.

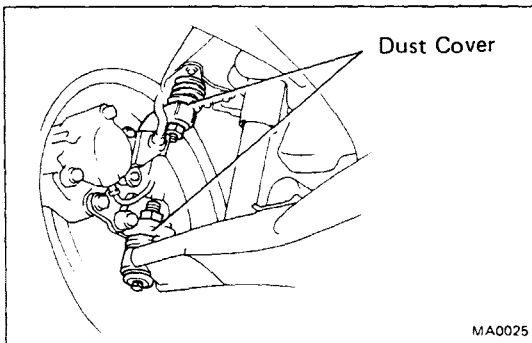

MA0025

**21. RN 2WD ONLY: INSPECT BALL JOINTS AND DUST COVERS**

- (a) Inspect the ball joints for excessive looseness. (See page FA-13)
- (b) Inspect the dust cover for damage.

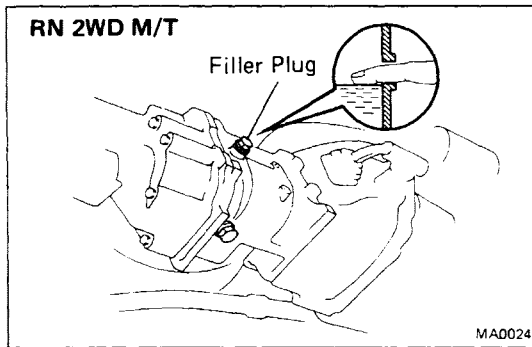

MA0024

**22. CHECK OIL LEVEL IN MANUAL TRANSMISSION, TRANSFER (RN 4WD ONLY) AND DIFFERENTIAL**

Remove the filler plug and feel inside the hole with your finger. Check that the oil comes to within 5 mm (0.20 in.) of the bottom edge of the hole. If the level is low, add oil until it begins to run out of the filler hole.

Transmission oil –

Oil grade: API GL-4 or GL-5  
Viscosity: SAE 75W-90

Transfer oil –

Oil grade: API GL-4 or GL-5  
Viscosity: SAE 75W-90

Differential oil –

Oil grade: API GL-5 hypoid gear oil  
Viscosity: Above –18°C (0°F) SAE 90  
Below –18°C (0°F) SAE 80W-90 or 80W

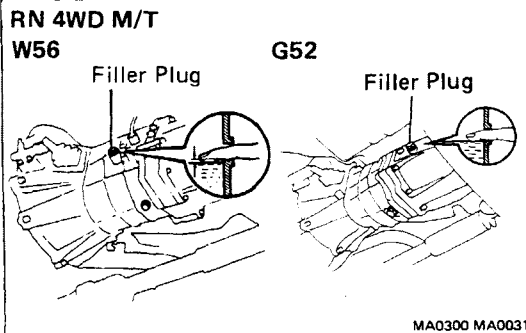

MA0300 MA0031

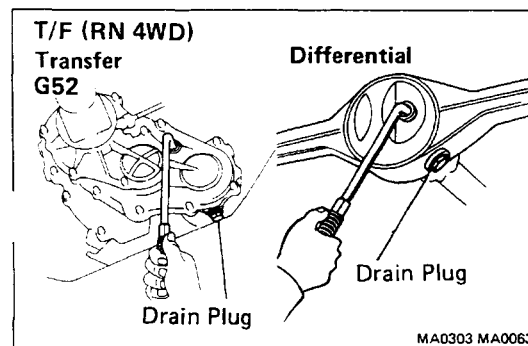
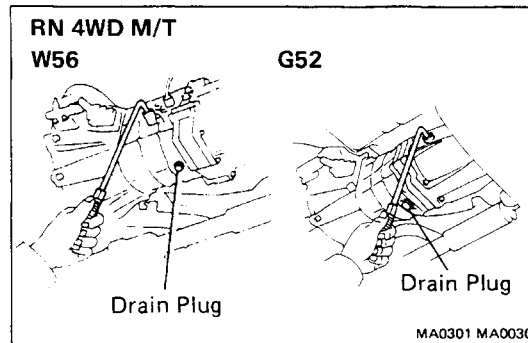
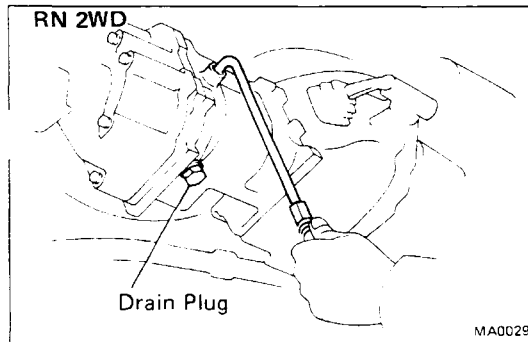
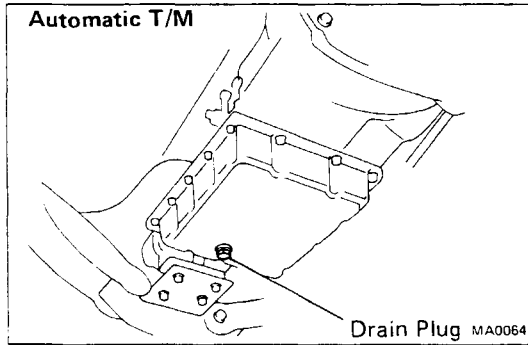
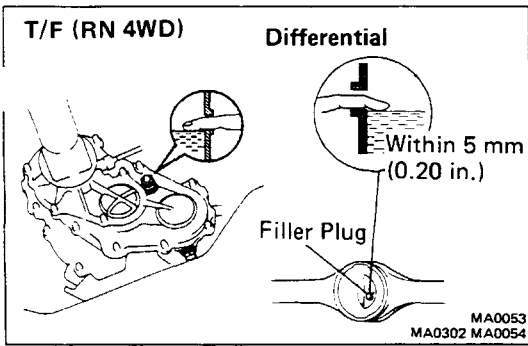

**23. CHECK AUTOMATIC TRANSMISSION OIL**

Check the automatic transmission for oil leakage. If leakage is found, check for cause and repair.

**24. REPLACE MANUAL TRANSMISSION, TRANSFER (RN 4WD) AND DIFFERENTIAL OIL**

- (a) Remove the drain plug and drain the oil.
- (b) Reinstall the drain plug.
- (c) Add new oil until it begins to run out of the filler hole.

**Oil grade and viscosity:** See page MA-12

**Oil capacity:**

**Transmission —**

**RN 2WD**

**W46, 55, 56**

2.4 liters (2.5 US qts, 2.1 Imp. qts)

**RN 4WD**

**G52**

3.9 liters (4.1 US qts, 3.4 Imp. qts)

**W56**

3.0 liters (3.2 US qts, 2.6 Imp. qts)

**Transfer — 1.6 liters (1.7 US qts, 1.4 Imp. qts)**

**Differential —**

**RN 2WD**

**7.5 in.**

1.7 liters (1.8 US qts, 1.5 Imp. qts)

**8.0 in.**

1.8 liters (1.9 US qts, 1.6 Imp. qts)

**RN 4WD**

**Front**

2.3 liters (2.4 US qts, 2.0 Imp. qts)

**Rear**

2.2 liters (2.3 US qts, 1.9 Imp. qts)

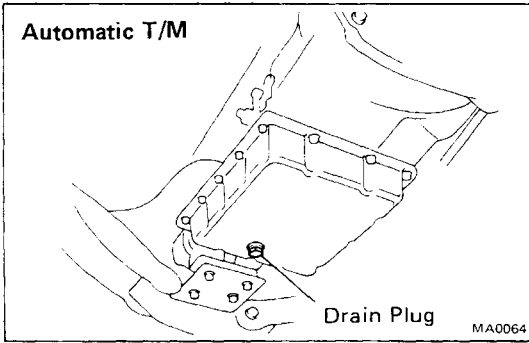

**25. RN 2WD ONLY:**

**REPLACE AUTOMATIC TRANSMISSION FLUID**

- (a) Remove the drain plug and drain the fluid.
- (b) Reinstall the drain plug securely.
- (c) With the engine OFF, add new fluid through the dipstick tube.

**Fluid: ATF DEXRON® II**

**Drain and refill capacity:**

2.4 liters (2.5 US qts, 2.1 Imp. qts)

**Dry fill capacity:**

6.5 liters (6.9 US qts, 5.7 Imp. qts)

- (d) Start the engine and shift the selector into all positions from P through L and then shift into P.
- (e) With the engine idling, check the fluid level. Add fluid up to the cool level on the dipstick.

**CAUTION: Do not overfill.**

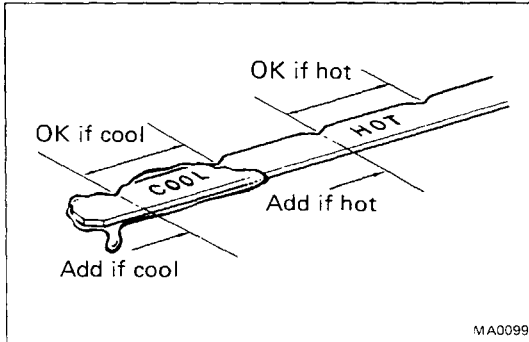

**RN 2WD  
SEE PAGE FA-7 to 9**

**26. REPACK FRONT WHEEL BEARINGS**

Change the front wheel bearing grease.

RN 2WD — (See page FA-7 to 19)

RN 4WD — (See page FA-44 to 47)

**RN 2WD —**

**Grease grade: Lithium base multipurpose grease (NLGI No.2)**

**Wheel bearing friction preload (at starting):**

0.6 — 1.8 kg (1.3 — 4.0 lb, 5.9 — 17.7 N)

**RN 4WD —**

**Grease grade: Lithium base multipurpose grease (NLGI No.2)**

**Wheel bearing friction preload (at starting):**

2.8 — 5.6 kg (6.2 — 12.3 lb, 27 — 55 N)

**RN 4WD  
SEE PAGE FA-44 to 47**

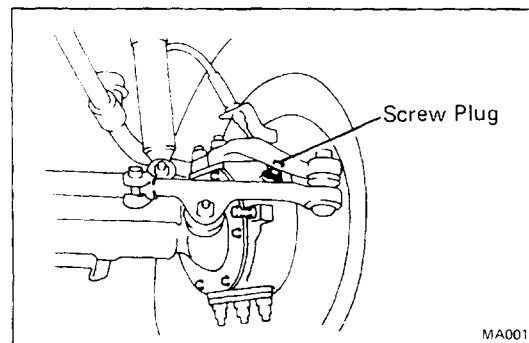

**27. RN 4WD ONLY:**

**LUBE STEERING KNUCKLE AND CHASSIS**

**(Including propeller shaft)**

- (a) Remove the screw plug from each steering knuckle and repack with lubricant.

**Steering knuckle grease: Molybdenum disulphide lithium base grease (NLGI No.2)**

- (b) Reinstall the two screw plugs.

- (c) Lubricate chassis components, referring to the lubrication chart. Before pumping in grease, wipe off any mud and dust on the grease fitting.

**Grease grade:**

**Propeller shaft (except Double-Cardan joint) — Lithium base chassis lubricant (NLGI No.2)**

**Double-Cardan joint — Molybdenum disulphide lithium base chassis lubricant (NLGI No.2)**

**Drag link ends —**

**Lithium base chassis lubricant (NLGI No.1)**

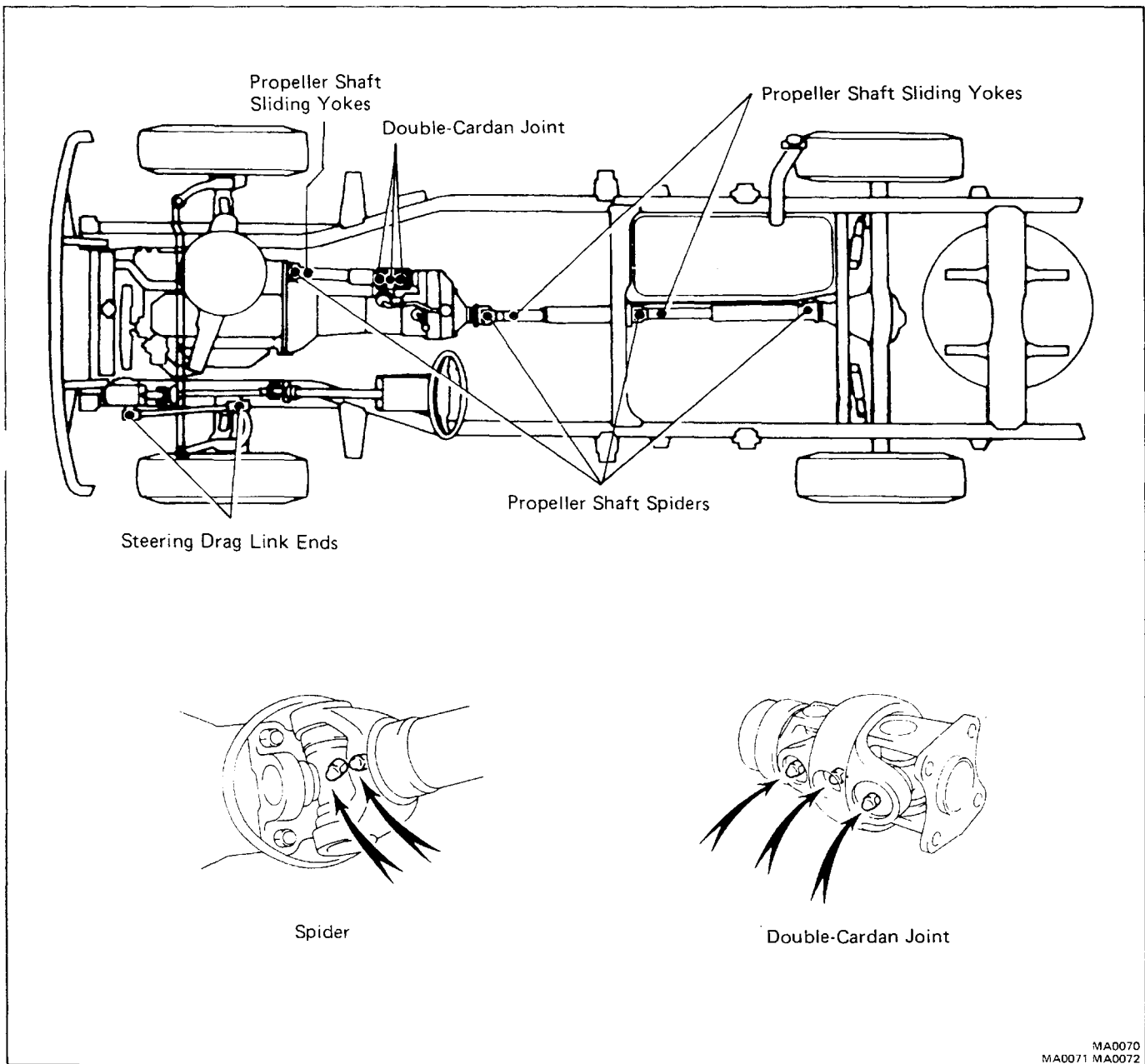

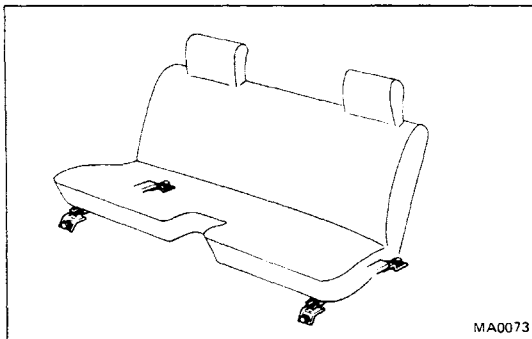

## 28. TIGHTEN BOLTS AND NUTS ON CHASSIS AND BODY

Tighten the following parts:

- Seat mounting bolts

**Torque: 375 kg-cm (27 ft-lb, 37 N·m)**

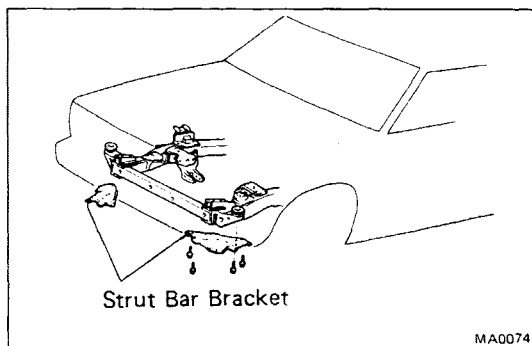

- Strut bar bracket-to-frame mounting bolts (RN 2WD)

**Torque: 530 kg-cm (38 ft-lb, 52 N·m)**

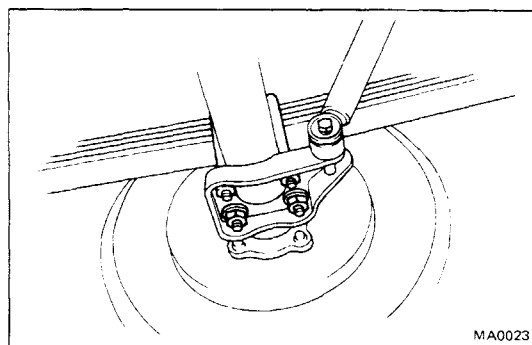

- Leaf spring U-bolt mounting nuts

**Torque:**

**RN 2WD 1,000 kg-cm (72 ft-lb, 98 N·m)**

**RN 4WD 1,250 kg-cm (90 ft-lb, 123 N·m)**

**Under Severe Condition:**

In addition to the above maintenance items, check for loose or missing bolts and nuts on the following:

- Steering system
- Drive train
- Suspension system
- Fuel tank mounts
- Engine mounts, etc.

**29. FINAL INSPECTION**

- (a) Check operation of body parts:
  - Hood
    - Auxiliary catch operates properly
    - Hood locks securely when closed
  - Doors
    - Door locks operate properly
    - Doors close properly
  - Seats
    - Seats adjust easily and lock securely in any positions
    - Seat backs lock securely at any angle
    - Fold-down seat backs lock securely
- (b) Road test
  - Engine and chassis parts do not have abnormal noises.
  - Vehicle does not wander or pull to one side.
  - Brakes work properly and do not drag.
- (c) Be sure to deliver a clean vehicle and especially check:
  - Steering wheel
  - Shift lever knob
  - All switch knobs
  - Door handles
  - Seats

## GENERAL MAINTENANCE

These are maintenance and inspections items which are considered to be the owner's responsibility. They can be performed by the owner or he can have them done at a service shop. These items include those which should be checked on a daily basis, those which, in most cases, do not require (special) tools and those which are considered to be reasonable for the owner to perform. Items and procedures for general maintenance are as follows.

### OUTSIDE VEHICLE

#### 1. TIRES

- (a) Check the pressure with a gauge. If necessary, adjust.
- (b) Check for cuts, damage or excessive wear.

#### 2. WHEEL NUTS

When checking the tires, check the nuts for looseness or for missing nuts. If necessary, tighten them.

#### 3. TIRE ROTATION

It is recommended that the tires be rotated every 7,500 miles (12,000 km).

#### 4. WINDSHIELD WIPER BLADES

Check for wear or cracks whenever they do not wipe clean. If necessary replace.

#### 5. FLUID LEAKS

- (a) Check underneath for leaking fuel, oil, water or other fluid.
- (b) If you smell gasoline fumes or notice any leak, have the cause found and corrected.

#### 6. DOORS AND ENGINE HOOD

- (a) Check that all doors and the tailgate operate smoothly, and that all latches lock securely.
- (b) Check that the engine hood secondary latch secures the hood from opening when the primary latch is released.

### INSIDE VEHICLE

#### 7. LIGHTS

- (a) Check that the headlights, stop lights, taillights, turn signal lights, and other lights are all working.

- (b) Check the headlight aim.

#### 8. WARNING LIGHTS AND BUZZERS

Check that all warning lights and buzzers function properly.

#### 9. HORN

Check that it is working.

#### 10. WINDSHIELD GLASS

Check for scratches, pits or abrasions.

#### 11. WINDSHIELD WIPER AND WASHER

- (a) Check operation of the wipers and washer.
- (b) Check that the wipers do not streak.

#### 12. WINDSHIELD DEFROSTER

Check that air comes out from the defroster outlet when operating the heater or air conditioner.

#### 13. REAR VIEW MIRROR

Check that it is mounted securely.

#### 14. SUN VISORS

Check that they move freely and are mounted securely.

#### 15. STEERING WHEEL

Check that it has specified freeplay. Be alert for changes in steering condition, such as hard steering, excessive freeplay or strange noise.

#### 16. SEATS

- (a) Check that the seat adjusters operate smoothly.
- (b) Check that all latches lock securely in any position.
- (c) Check that the head restraints move up and down smoothly and that the locks hold securely in any latched position.
- (d) For fold-down seat backs, check that the latches lock securely.

#### 17. SEAT BELTS

- (a) Check that the seat belt system such as the buckles, retractors and anchors operate properly and smoothly.
- (b) Check that the belt webbing is not cut, frayed, worn or damaged.

**18. ACCELERATOR PEDAL**

Check the pedal for smooth operation and un-even pedal effort or catching.

**19. CLUTCH PEDAL (See page CL-3)**

Check the pedal for smooth operation.  
Check that the pedal has the proper freeplay.

**20. BRAKE PEDAL (See page BR-5)**

- (a) Check the pedal for smooth operation.
- (b) Check that the pedal has the proper reserve distance and freeplay.
- (c) Check the brake booster function.

**21. BRAKES**

At a safe place, check that the brakes do not pull to one side when applied.

**22. PARKING BRAKE (See page BR-7)**

- (a) Check that the lever has the proper travel.
- (b) On a safe incline, check that vehicle is held securely with only the parking brake applied.

**23. AUTOMATIC TRANSMISSION "PARK" MECHANISM**

- (a) Check the lock release button of the selector lever for proper and smooth operation.
- (b) On a safe incline, check that vehicle is held securely with the selector lever in "P" position and all brakes released.

**UNDER HOOD**

**24. WINDSHIELD WASHER FLUID**

Check that there is sufficient fluid in the tank.

**25. ENGINE COOLANT LEVEL**

Check that the coolant level is between the "FULL" and "LOW" lines on the see-through reservoir.

**26. RADIATOR AND HOSES**

- (a) Check that the front of the radiator is clean and not blocked with leaves, dirt or bugs.
- (b) Check the hoses for cracks, kinks, rot or loose connections.

**27. BATTERY ELECTROLYTE LEVEL**

Check that the electrolyte level of all battery cells is between the upper and lower level

lines on the case. If level is low, add distilled water only.

**28. BRAKE AND CLUTCH FLUID LEVELS**

- (a) Check that the brake fluid level is near the upper level line on the see-through reservoir.
- (b) Check that the clutch fluid level is up to the top of the narrow neck of the see-through reservoir.

**29. ENGINE DRIVE BELTS**

Check all drive belts for fraying, cracks, wear or oiliness.

**30. ENGINE OIL LEVEL**

Check the level on the dipstick with the engine turned off.

**31. POWER STEERING FLUID LEVEL**

Check the level on the dipstick. The level should be in the "HOT" or "COLD" range depending on the fluid temperature.

**32. AUTOMATIC TRANSMISSION FLUID LEVEL**

- (a) Park the vehicle on a level surface.
- (b) With the engine idling and the parking brake applied, shift the selector into all positions from P to L, and then shift into P.
- (c) Pull out the dipstick and wipe off the fluid with a clean rag. Re-insert the dipstick and check that the fluid level is in the HOT range.
- (d) Perform this check with the fluid at normal driving temperature (70 — 80°C or 158 — 176°F).

NOTE: Wait until the engine cools down (about 30 min.) before checking the fluid level after extended high speed driving in hot weather, driving in heavy traffic or pulling a trailer.

**33. EXHAUST SYSTEM**

Visually inspect for cracks, holes or loose supports. If any change in the sound of the exhaust or smell of the exhaust fumes is noticed, have the cause located and corrected.