

1985 TOYOTA TRUCK & 4-RUNNER Gasoline REPAIR MANUAL

| | |
|---|----|
| INTRODUCTION | IN |
| MAINTENANCE | MA |
| ENGINE MECHANICAL | EM |
| EMISSION CONTROL SYSTEM | EC |
| EFI SYSTEM | FI |
| FUEL SYSTEM | FU |
| COOLING SYSTEM | CO |
| LUBRICATION SYSTEM | LU |
| IGNITION SYSTEM | IG |
| STARTING SYSTEM | ST |
| CHARGING SYSTEM | CH |
| CLUTCH | CL |
| MANUAL TRANSMISSION | MT |
| AUTOMATIC TRANSMISSION | AT |
| TRANSFER | TF |
| PROPELLER SHAFT | PR |
| FRONT AXLE AND SUSPENSION | FA |
| REAR AXLE AND SUSPENSION | RA |
| BRAKE SYSTEM | BR |
| STEERING | SR |
| BODY ELECTRICAL SYSTEM | BE |
| BODY | BO |
| WINCH | WI |
| AIR CONDITIONING SYSTEM | AC |
| SERVICE SPECIFICATIONS | A |
| STANDARD BOLT TIGHTENING TORQUE | B |
| SST AND SSM | C |
| AUTOMATIC TRANSMISSION HYDRAULIC CIRCUIT | D |
| ELECTRICAL WIRING DIAGRAMS | E |

INTRODUCTION

| | Page |
|---|------|
| HOW TO USE THIS MANUAL | IN-2 |
| IDENTIFICATION INFORMATION | IN-4 |
| GENERAL REPAIR INSTRUCTIONS | IN-4 |
| PRECAUTIONS FOR VEHICLES EQUIPPED WITH A CATALYTIC CONVERTER | IN-7 |
| VEHICLE LIFT AND SUPPORT LOCATIONS | IN-8 |
| ABBREVIATIONS USED IN THIS MANUAL | IN-9 |

IN

HOW TO USE THIS MANUAL

To assist in finding your way through the manual, the Section Title and major heading are given at the top of every page.

An **INDEX** is provided on the first page of each section to guide you to the item to be repaired.

At the beginning of each section, **PRECAUTIONS** are given that pertain to *all* repair operations contained in that section. *Read these precautions before starting any repair task.*

TROUBLESHOOTING tables are included for each system to help you diagnose the system problem and find the cause. The repair for each possible cause is referenced in the remedy column to quickly lead you to the solution.

REPAIR PROCEDURES

Most repair operations begin with an overview illustration. It identifies the components and shows how the parts fit together.

Example:

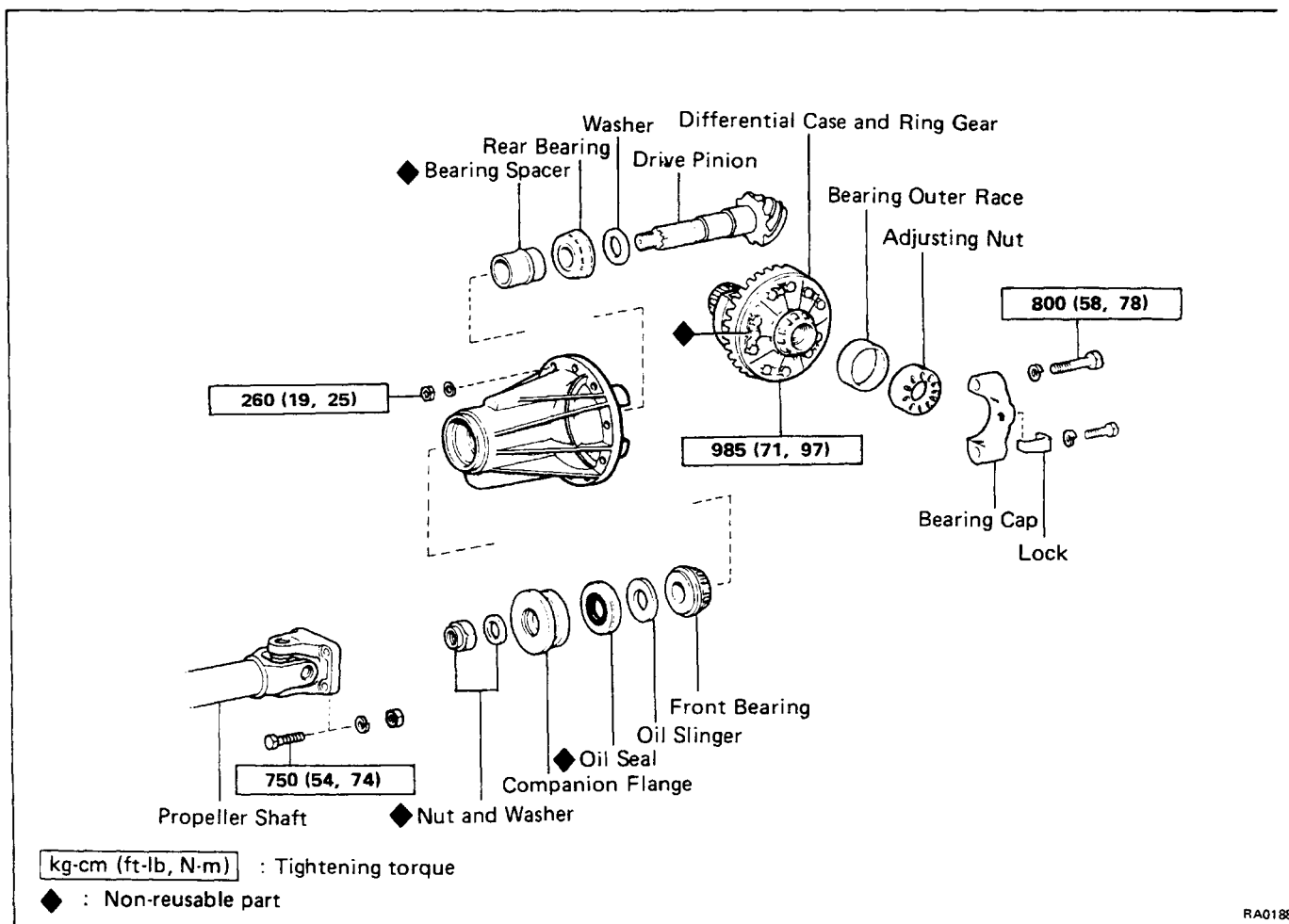

The procedures are presented in a step-by-step format:

- The photo or illustration shows *what* to do and *where* to do it.
- The task heading tells *what* to do.
- The detailed text tells *how* to perform the task and gives other information such as specifications and warnings.

Example:

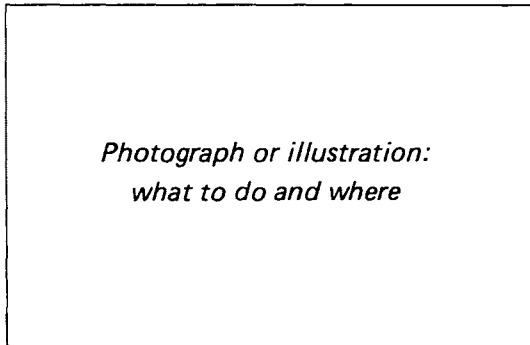

Task heading: what to do

INSTALL DRIVE SHAFT ON CENTER SUPPORT BEARING FLANGE

- (a) Align the marks on the flanges and connect the flanges with four bolts and nuts.
- (b) Torque the bolts and nuts.

Torque: 750 kg-cm (54 ft-lb, 74 N·m) *Detail text: how to do it*

Specification

This format enables the experienced technician to have a FAST TRACK. He can read the task headings and only refer to the detailed text when he needs it. Important specifications and warnings always stand out in bold type.

REFERENCES

References have been kept to a minimum. However, when they are required you are given the *page* to go to.

SPECIFICATIONS

Specifications are presented in bold type throughout the text in the applicable step. You never have to leave the procedure to look up your specs. All specifications are also found in Appendix A, specifications for quick reference.

WARNINGS, CAUTIONS, NOTES:

- **WARNINGS** are presented in bold type, and indicate there is a possibility of injury to you or other people.
- **CAUTIONS** are also presented in bold type, and indicate the possibility of damage to the components being repaired.
- **NOTES** are separated from the text but do not appear in bold. They provide additional information to help you efficiently perform the repair.

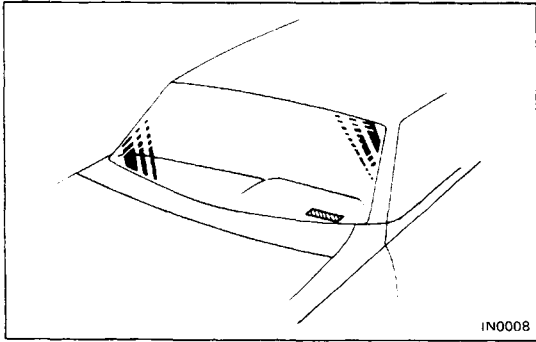

IDENTIFICATION INFORMATION

VEHICLE IDENTIFICATION NUMBER

The vehicle identification number is stamped on top of the instrument panel.

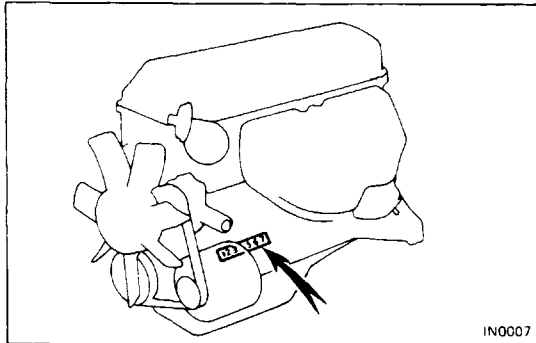

ENGINE SERIAL NUMBER

The engine serial number is stamped on the left side of the cylinder block.

GENERAL REPAIR INSTRUCTIONS

1. Use fender seat and floor covers to keep the vehicle clean and prevent damage.
2. During disassembly, keep parts in order to facilitate re-assembly.
3. Observe the following:
 - (a) Before performing electrical work, disconnect the cable from the battery terminal.
 - (b) If it is necessary to disconnect the battery for inspection or repair, always disconnect the cable from the negative (–) terminal which is grounded to the vehicle body.
 - (c) To prevent damage to the battery terminal post, loosen the terminal nut and raise the cable straight up without twisting it or prying it.
 - (d) Clean the battery terminal posts and cable terminals with a shop rag. Do not scrape them with a file or such.
 - (e) Install the cable terminal to the battery post with the nut loose, and tighten the nut after installation. Do not use a hammer or such to tap the terminal onto the post.
 - (f) Be sure the cover for the positive (+) terminal is properly in place.
4. Check hose and wiring connectors to make sure that they are secure and correct.

5. Non-reusable Parts

- (a) Always replace cotter pins, gaskets, O-rings and oil seals etc. with new ones.
- (b) Non-reusable parts are indicated in the component illustrations by the symbol "◆".

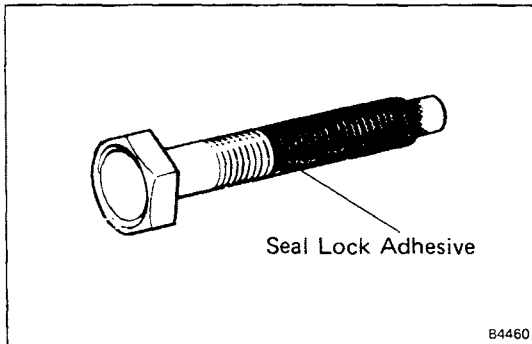

6. Precoated Parts

Precoated parts are the bolts, nuts, etc. which are coated with a seal lock adhesive at the factory.

- (a) If a precoated part is tightened, loosened or caused to move in any way, it must be recoated with the specified adhesive.
- (b) Recoating of Precoated Parts
 - (1) Clean off the old adhesive from the bolt, nut or installation part threads.
 - (2) Dry with compressed air.
 - (3) Apply the specified seal lock adhesive to the bolt or nut threads.
- (c) Precoated parts are indicated in the component illustrations by the symbol "★".

7. When necessary, use a sealer on gaskets to prevent leaks.
8. Carefully observe all specifications for bolt tightening torques. Always use a torque wrench.
9. Use of special service tools (SST) and special service materials (SSM) may be required, depending on the nature of the repair. Be sure to use SST and SSM where specified and follow the proper work procedure. A list of SST and SSM can be found at the back of this manual.
10. When replacing fuses, be sure the new fuse is the correct amperage rating. DO NOT exceed the fuse amp rating or use one of a lower rating.
11. Care must be taken when jacking up and supporting the vehicle. Be sure to lift and support the vehicle at the proper locations. (See page IN-8)
 - (a) If the vehicle is to be jacked up only at the front or rear end, be sure to block the wheels in order to ensure safety.
 - (b) After the vehicle is jacked up, be sure to support it on stands. It is extremely dangerous to do any work on the vehicle raised on jack alone, even for a small job that can be finished quickly.

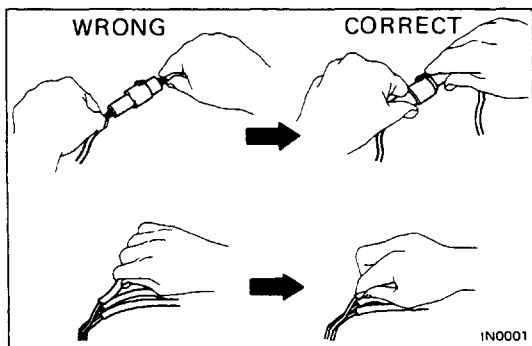

12. Observe the following precautions to avoid damage to the parts:

- (a) To disconnect vacuum hoses, pull on the end, not the middle of the hose.
- (b) To pull apart electrical connectors, pull on the connector itself, not the wires.
- (c) Be careful not to drop electrical components, such as sensors or relays. If they are dropped on a hard floor, they should be replaced and not reused.
- (d) When steam cleaning an engine, protect the distributor, coil, air filter, carburetor intake, air pump and VCV from water.
- (e) Never use an impact wrench to remove or install thermo switches or thermo sensors.
- (f) When checking continuity at the wire connector, insert the tester probe carefully to prevent terminals from bending.
- (g) When using a vacuum gauge, never force the hose onto a connector that is too large. Use a step-down adapter instead. Once the hose has been stretched, it may leak.

13. Tag hoses before disconnecting them:

- (a) When disconnecting vacuum hoses, use tags to identify how they should be reconnected.
- (b) After completing a job, double check that the vacuum hoses are properly connected. A label under the hood shows the proper layout.

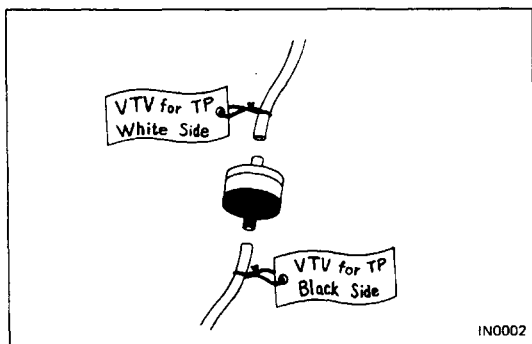

PRECAUTIONS FOR VEHICLES EQUIPPED WITH A CATALYTIC CONVERTER

WARNING: If large amounts of unburned gasoline flow into the converter, it may overheat and create a fire hazard. To prevent this, observe the following precautions and explain them to your customer.

1. **Use only unleaded gasoline.**
2. **Avoid prolonged idling.**
Avoid running the engine at fast idle speed for more than 10 minutes and at idle speed for more than 20 minutes.
3. **Avoid spark jump test.**
 - (a) Spark jump test only when absolutely necessary. Perform this test as rapidly as possible.
 - (b) While testing, never race the engine.
4. **Avoid prolonged engine compression measurement.**
Engine compression tests must be made as rapidly as possible.
5. **Do not run engine when fuel tank is nearly empty.**
This may cause the engine to misfire and create an extra load on the converter.
6. **Avoid coasting with ignition turned off and prolonged braking.**
7. **Do not dispose of used catalyst along with parts contaminated with gasoline or oil.**

VEHICLE LIFT AND SUPPORT LOCATIONS

[4WD]

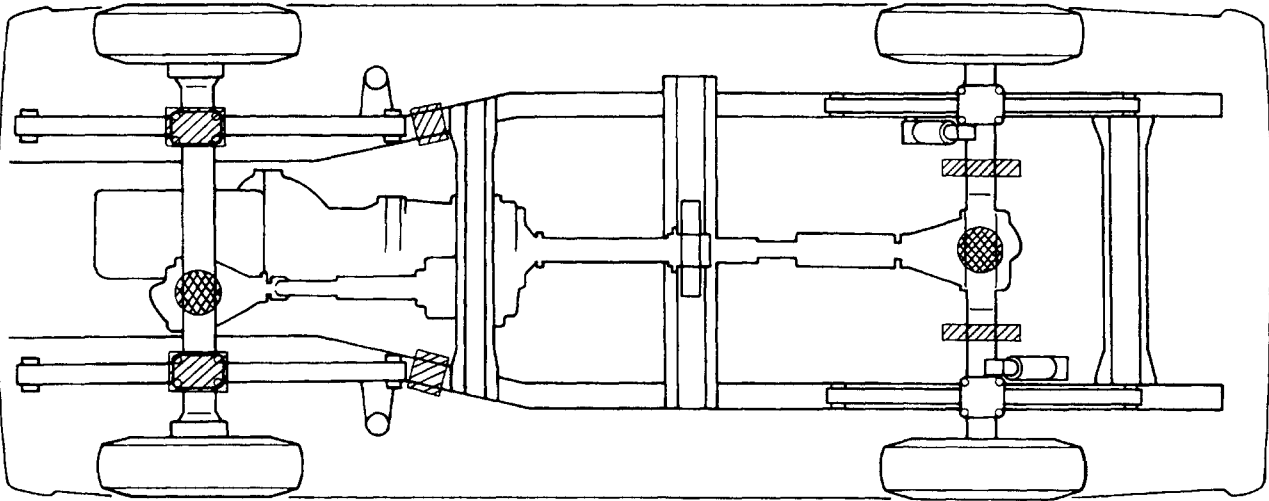

[2WD]

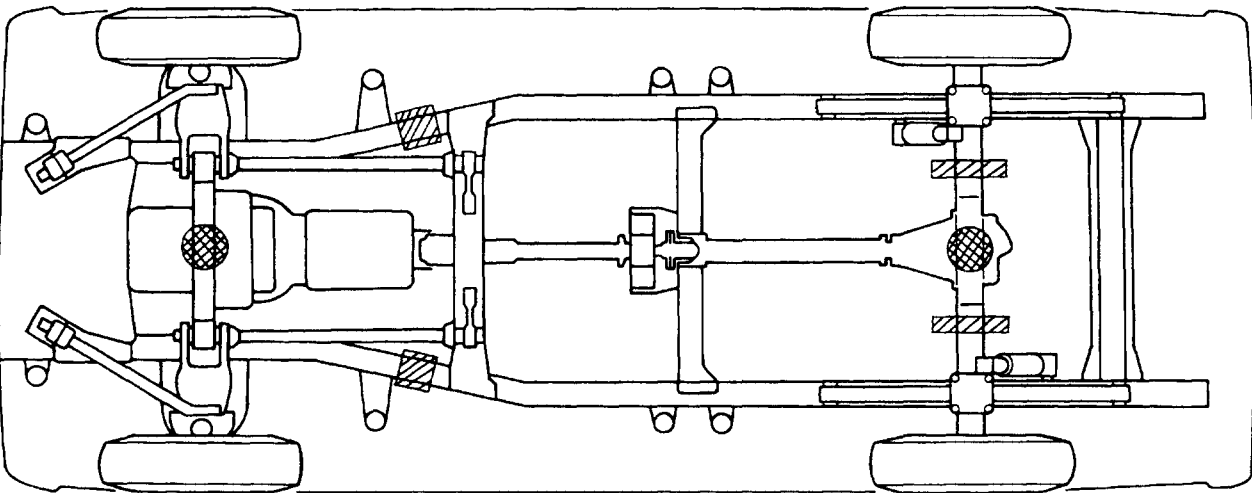

JACK POSITION 

- Front [2WD] Center of crossmember
- [4WD] Center of front axle housing
- Rear Center of rear axle housing

SUPPORT POSITION

Safety stand 

ABBREVIATIONS USED IN THIS MANUAL

| | |
|----------|--|
| AAP | Auxiliary Acceleration Pump |
| A/C | Air Conditioner |
| AI | Air Injection |
| APPROX. | Approximate |
| AS | Air Suction |
| A/T, ATM | Automatic Transmission |
| ATF | Automatic Transmission Fluid |
| BTDC | Before Top Dead Center |
| BVSV | Bi-metal Vacuum Switching Valve |
| CALIF. | Vehicles Sold in California |
| CB | Choke Breaker |
| C&C | Cab and Chassis |
| CMH | Cold Mixture Heater |
| DP | Dash Pot |
| EACV | Electronic Air Control Valve |
| ECU | Electronic Control Unit |
| EFI | Electronic Fuel Injection |
| EGR | Exhaust Gas Recirculation |
| ESA | Electronic Spark Advance |
| EVAP | Evaporative (Emission Control) |
| EX | Exhaust (manifold, valve) |
| Ex. | Except |
| FED. | Vehicles Sold in USA except California |
| HAC | High Altitude Compensation |
| HAI | Hot Air Intake |
| IN | Intake (manifold, valve), Inch |
| IG | Ignition |
| LH | Left-hand |
| MAS | Mixture Adjusting Screw |
| MC | Mixture Control |
| MP | Multipurpose |
| M/T, MTM | Manual Transmission |
| OC | Oxidation Catalyst |
| OD | Overdrive |
| OPT | Option |
| O/S | Oversized |
| PCV | Positive Crankcase Ventilation |
| PS | Power Steering |
| RH | Right-hand |
| SC | Spark Control |
| SSM | Special Service Materials |
| SST | Special Service Tools |
| STD | Standard |
| S/W | Switch |
| TCCS | Toyota Computer Control System |
| TDC | Top Dead Center |
| TWC | Three Way Catalyst |
| U/S | Undersized |
| VCS | Vacuum Control Switch |
| VCV | Vacuum Control Valve |
| VSV | Vacuum Switching Valve |
| VTV | Vacuum Transmitting Valve |
| 2WD | Two Wheel Drive Vehicles (4x2) |
| 4WD | Four Wheel Drive Vehicles (4x4) |
| Short | Short wheel base |
| Long | Long wheel base |
| w/ | With |
| w/o | Without |